

Pump Tank

Required where waste water must be pumped to sewer or to an elevated level. Pump tanks may include features such as quick-release camlock connectors, non-return valves, high-level alarms and a pre-wired control station junction box. Pipe arrangement and pump selection would be made according to the particular application or duty specified.

Dimensions mm

Capacity litres	A	B	C in	C out	D
90	450	450	450	450	550
200	600	600	600	600	750
400	750	750	750	750	900
700	900	900	900	900	1200

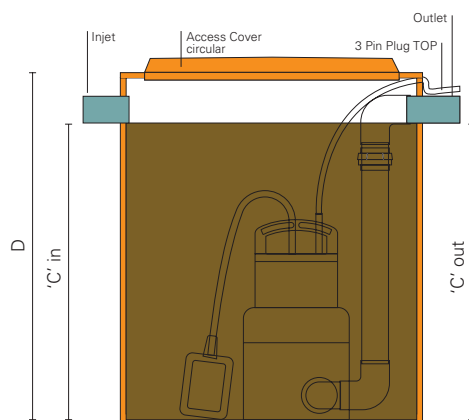

Section View

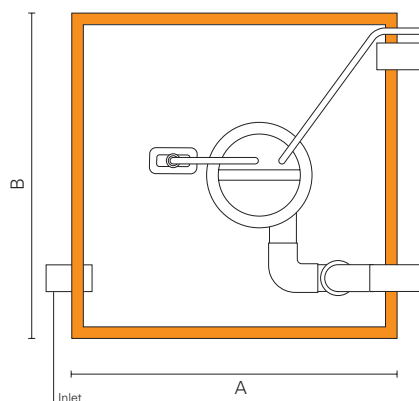

Plan View (without lid)

Pump Tank model HP-5

For above and below-ground installations

- Manufactured from PolyethylenePolypropylene – Panelim®, this tank is suitable for above or below-ground installations
- Above-ground tanks are fitted with a circular access cover
- Tank dimensions and pipework positions are nominal
- When space limitations dictate, equivalent capacity tanks can be manufactured to order
- Tank can be supplied with submersible pump suitable for a variety of waste applications

Note: Pumps supplied separately

Also available from Hugo Plastics

- Grease Interceptors for above and below-ground installations
- Mixing Tanks
- Settling Tanks
- Pump Tank
- Silt Pit
- Testing Sump
- Solvent and Oil Interceptor
- Petrol and Oil Interceptor
- Cooling and Straining Tank
- Custom Fabrication to order